

# Perfection<sup>®</sup>



"Based on the knowledge gathered in the sanding and finishing industry around the world since 1999, Alpha-Brush manufactures flexible abrasives technologies for a wide variety of sanding and polishing applications in the wood, metal and composites markets."

- Thorben Lundum



Let Alpha-Brush maximize **your sanding potential!**

 +45 40 40 73 37 or  
(678) 954-0530

 Frankrigsvej 22  
8450 Hammel, Denmark

 [info@alpha-brush.com](mailto:info@alpha-brush.com)

 [www.Alpha-Brush.com](http://www.Alpha-Brush.com)

**The Perfection line** of brush sanders is top of the line! These sanding machines can be ordered in a wide variety of sizes and configurations. Due to the variety of specific designs the machines integrate perfectly into a wide variety of applications in the wood market, metal processing, plastics, composites and much more.

These heavy-duty machines are designed and built to be run 24/7 in the most demanding conditions. The Perfection line of sanders can be configured with in-line sanding rollers for a lineal finish & a variety of disc station(s) configurations for a non-directional scratch. The Perfection range comes in sanding width 1350mm (53") up to 2450mm (96") & is also available as a top/bottom machine.

**Got a specific application? Give us a call, let us work with you to get the Perfect machine for your needs!**

**15" Color Touchscreen Control**

The machine features an easy and intuitive 15" control, mounted on a swivel for easy access from the front or from the side of the machine.

**Oscillating Disc Station**

Equipped with 150-250mm (6"-10") diameter discs with independent variable speed control of brush rotation, rotation direction and disc oscillation. The counter rotating and oscillating discs offer exceptional sanding across the entire surface, sanding in multiple directions for ultimate fiber removal and consistency on all surfaces. The unique discs are equipped with a combination of angled and straight keyways to help sand the outside as well as the inside edges of the workpiece and can accommodate single or double side abrasives for application flexibility.

**Helical Barrel Brush Station**

Equipped with barrel brushes of 250mm-400mm (10"- 16") diameter with variable speed control of brush rotation speed and rotation direction. The counter rotating barrel brushes sand in multiple directions for equal treatment of leading and trailing edges and are ideal for sanding thinner panels due to the centrifugal force created by the brush rotation speed. The helical keyways can accommodate single or double side abrasives for application flexibility.

**Vacuum Conveyor System**

Heavy duty fabricated conveyor bed in 1350mm (53") sanding width, equipped with a high-performance vacuum fan for secure vacuum hold down of small pieces as they pass through the machine. The unique vacuum table design ensures constant workpiece hold down throughout the entire conveyor bed, while the variable vacuum control system automatically adjusts vacuum to maintain constant pressure regardless of workpiece size or load efficiency.

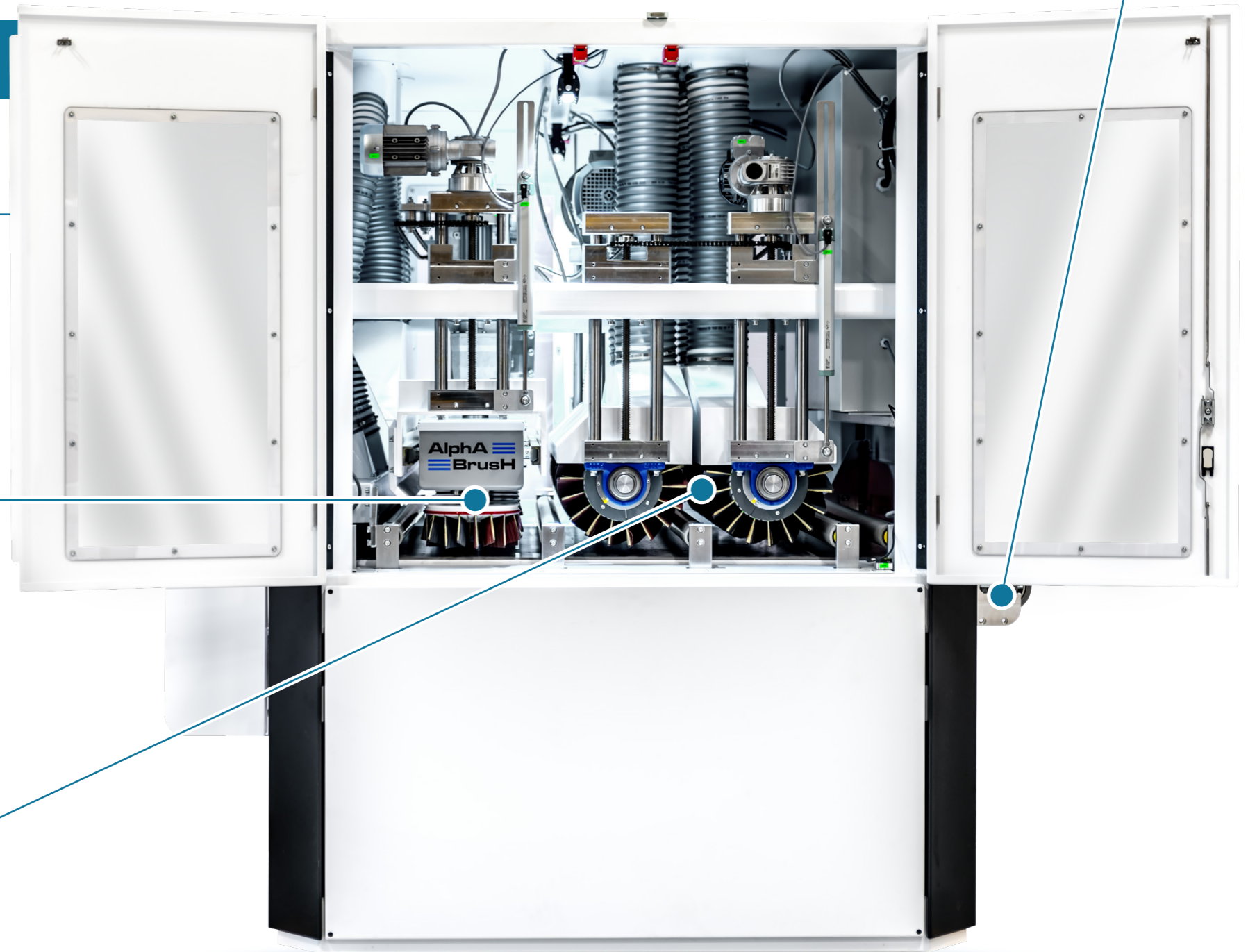

## PERFECTION SANDING STATIONS AVAILABLE

*B: Barrel Brush*



*BB: Double Barrel Brushes*



*D: Disc*

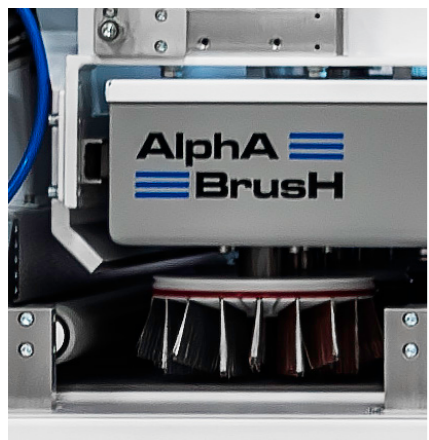

*DD: Double Disc*

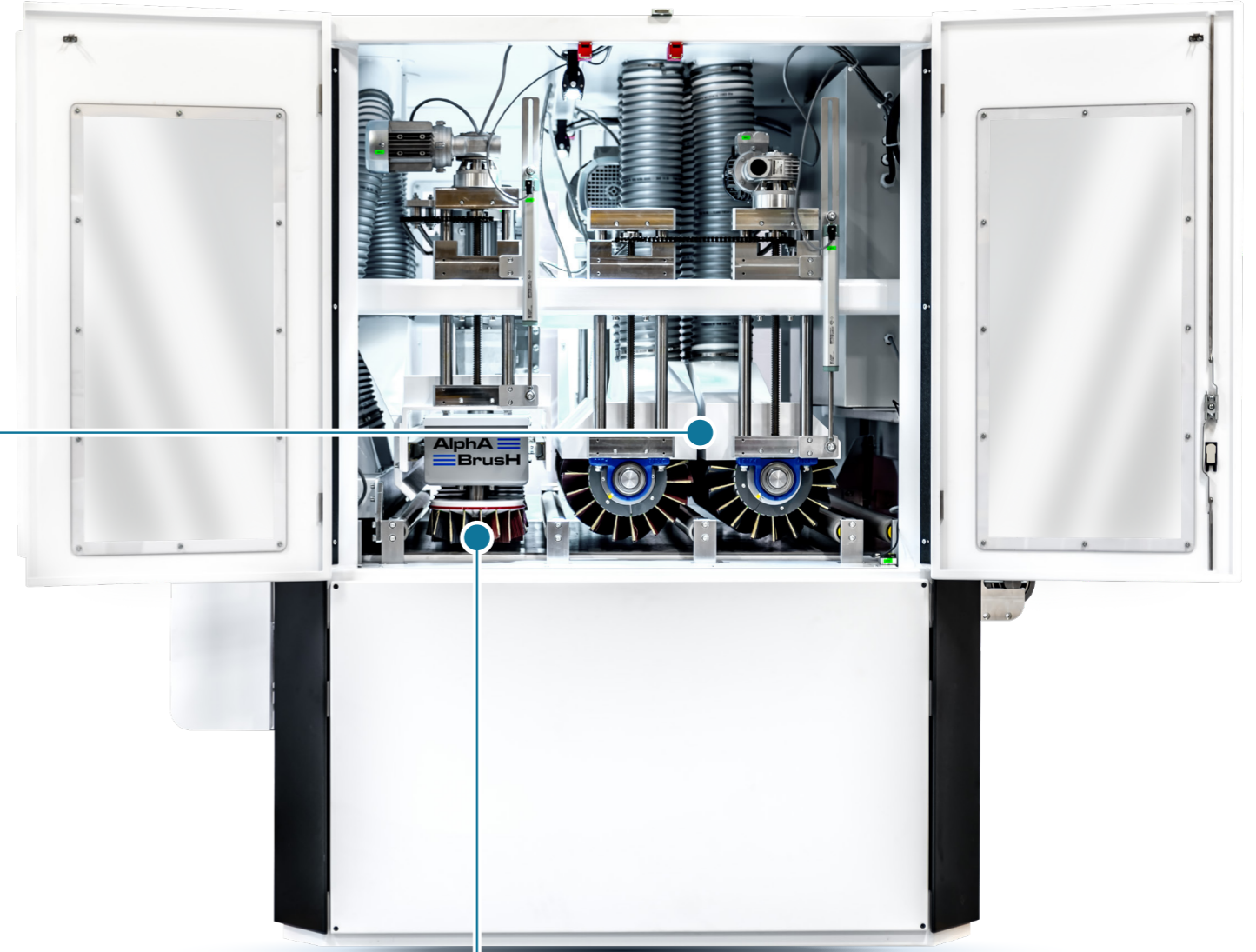
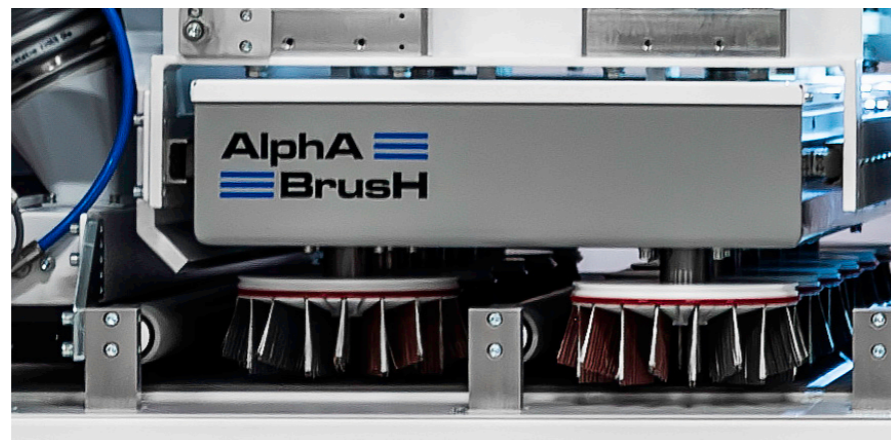

Perfection BB2DD

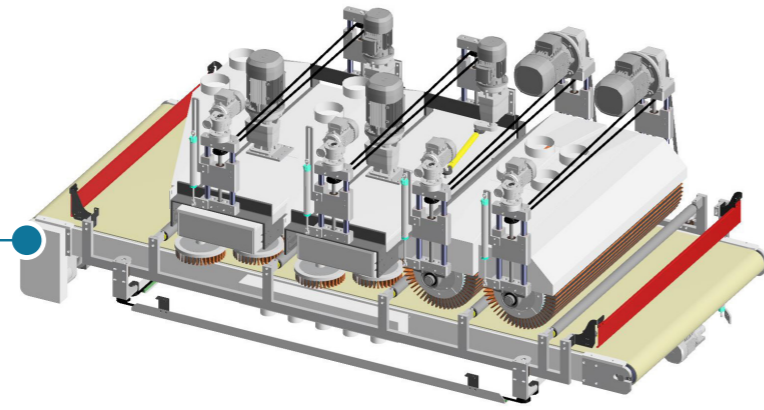

Perfection 2DD

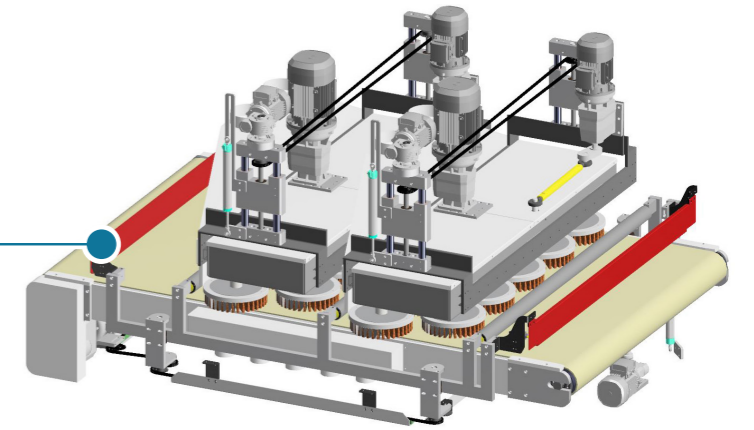

Perfection BBDD

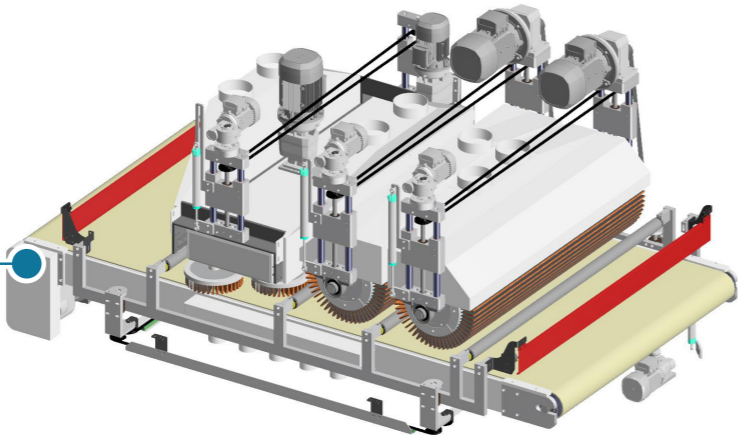

Perfection 2DDB

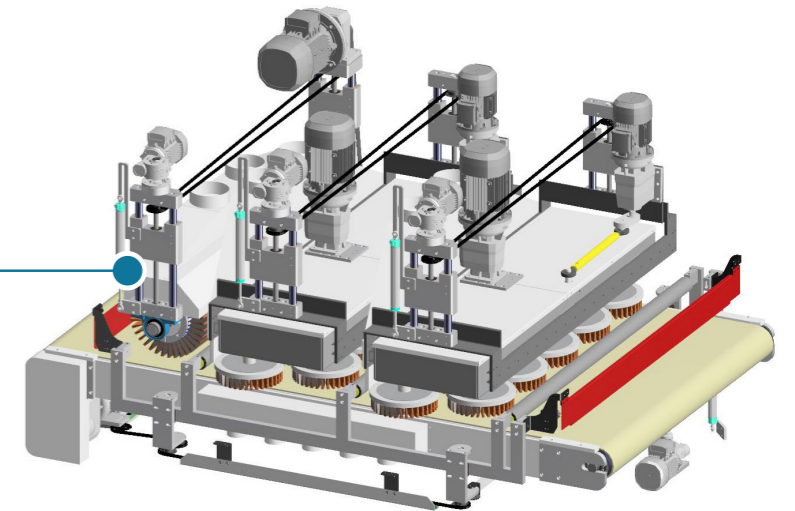

Perfection BBD

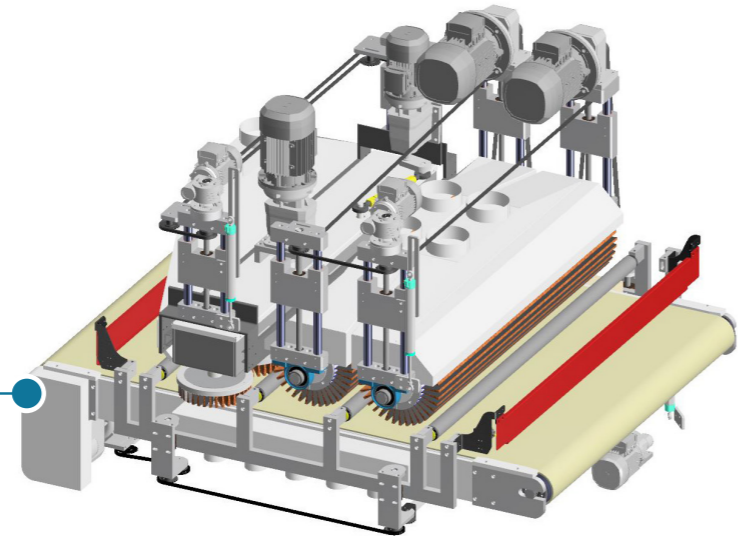

Perfection 3DD

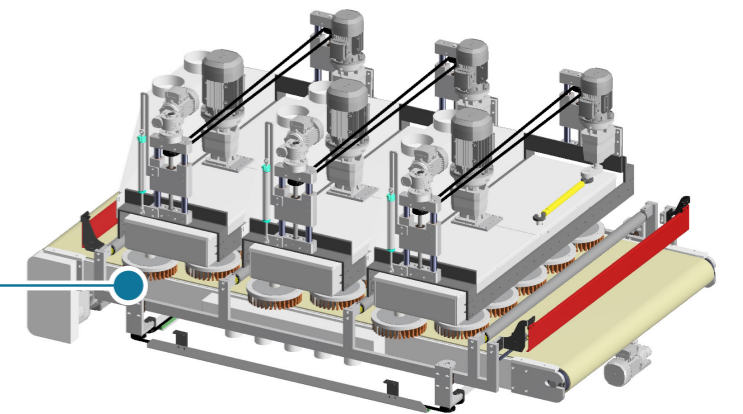

Perfection TB-4D

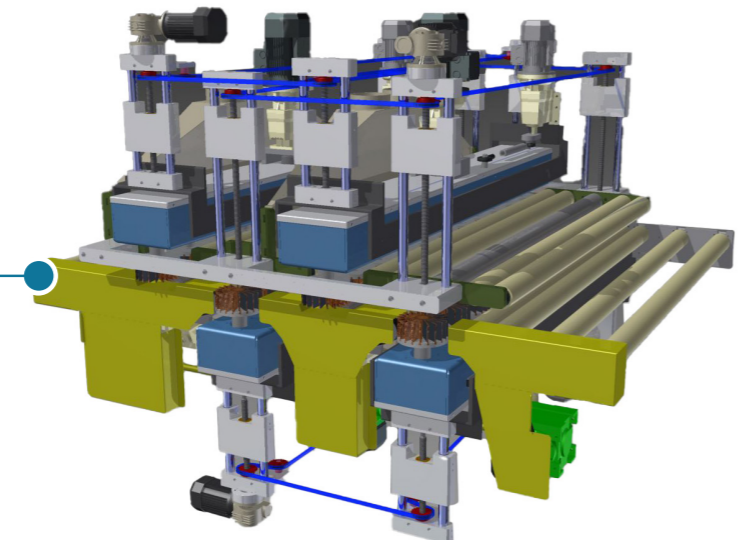

Perfection 4B

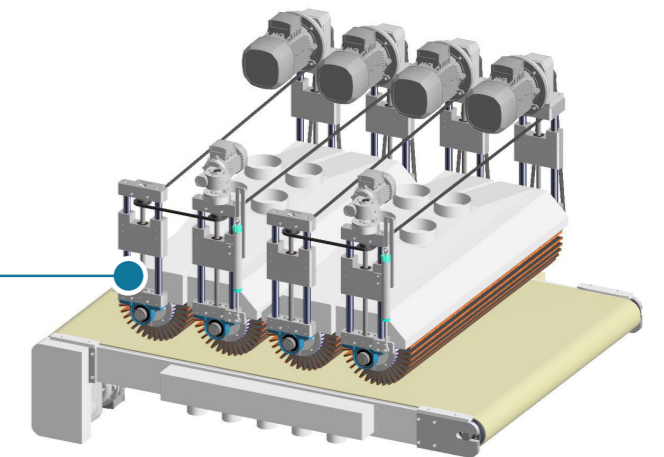

# Perfection<sup>®</sup>



"Based on the knowledge gathered in the sanding and finishing industry around the world since 1999, Alpha-Brush manufactures flexible abrasives technologies for a wide variety of sanding and polishing applications in the wood, metal and composites markets."

- Thorben Lundum



Let Alpha-Brush maximize **your sanding potential!**

 +45 40 40 73 37 or  
(678) 954-0530

 Frankrigsvej 22  
8450 Hammel, Denmark

 [info@alpha-brush.com](mailto:info@alpha-brush.com)

 [www.Alpha-Brush.com](http://www.Alpha-Brush.com)